

New Jersey Semi-Conductor Products, Inc.

20 STERN AVE.
SPRINGFIELD, NEW JERSEY 07081
U.S.A.

TELEPHONE: (973) 376-2922
(212) 227-6005
FAX: (973) 376-8960

**1N5719, 1N5767, 5082-3001, 5082-3039,
5082-3077, 5082-3080/81, 5082-3188, 5082-3379**
PIN Diodes for RF Switching and Attenuating

Features

- Low Harmonic Distortion
- Large Dynamic Range
- Low Series Resistance
- Low Capacitance

Maximum Ratings

Junction Operating and
Storage Temperature Range.....-65°C to +150°C
Power Dissipation 25°C.....250 mW
(Derate linearly to zero at 150°C)
Peak Inverse Voltage (PIV).....same as V_{BR}
Maximum Soldering Temperature.....260°C for 5 sec

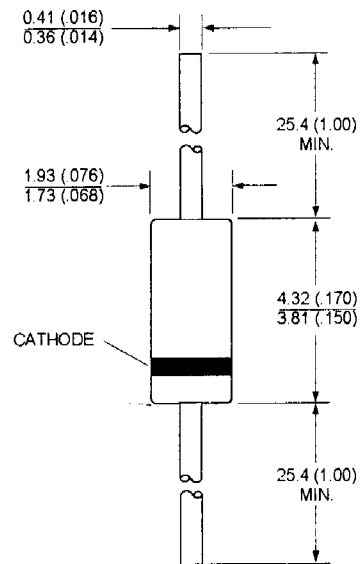

DIMENSIONS IN MILLIMETERS AND (INCHES).

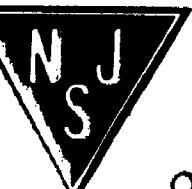

NJ Semi-Conductors reserves the right to change test conditions, parameters limits and package dimensions without notice information furnished by NJ Semi-Conductors is believed to be both accurate and reliable at the time of going to press. However NJ Semi-Conductors assumes no responsibility for any errors or omissions discovered in its use. NJ Semi-Conductors encourages customers to verify that datasheets are current before placing orders.

Quality Semi-Conductors

General Purpose Diodes

Electrical Specifications at $T_A = 25^\circ\text{C}$

Part Number 5082-	Maximum Total Capacitance C_T (pF)	Minimum Breakdown Voltage V_{BR} (V)	Maximum Residual Series Resistance R_S (Ω)	Effective Carrier Lifetime τ (ns)	Reverse Recovery Time t_{rr} (ns)
General Purpose Switching and Attenuating					
3001	0.25	200	1.0	100 (min.)	100 (typ.)
3039	0.25	150	1.25	100 (min.)	100 (typ.)
1N5719	0.3**	150	1.25	100 (min.)	100 (typ.)
3077	0.3	200	1.5	100 (min.)	100 (typ.)
Band Switching					
3188	1.0*	35	0.6**	70 (typ.)*	12 (typ.)
Test Conditions	$V_R = 50\text{ V}$ * $V_R = 20\text{ V}$ ** $V_R = 100\text{ V}$ $f = 1\text{ MHz}$	$V_R = V_{BR}$ Measure $I_R \leq 10\ \mu\text{A}$	$I_F = 100\text{ mA}$ * $I_F = 20\text{ mA}$ ** $I_F = 10\text{ mA}$ $f = 100\text{ MHz}$	$I_F = 50\text{ mA}$ $I_R = 250\text{ mA}$ * $I_F = 10\text{ mA}$ * $I_R = 6\text{ mA}$	$I_F = 20\text{ mA}$ $V_R = 10\text{ V}$ 90% Recovery

Notes:

Typical CW power switching capability for a shunt switch in a 50 Ω system is 2.5 W.

RF Current Controlled Resistor Diodes

Electrical Specifications at $T_A = 25^\circ\text{C}$

Part Number	Effective Carrier Lifetime τ (ns)	Min. Breakdown Voltage V_{BR} (V)	Max. Residual Series Resistance R_S (Ω)	Max. Total Capacitance C_T (pF)	High Resistance Limit, R_H (Ω)		Low Resistance Limit, R_L (Ω)		Max. Difference in Resistance vs. Bias Slope, Dc
					Min.	Max.	Min.	Max.	
5082-3080	1300 (typ.)	100	2.5	0.4	1000			8**	
1N5767*	1300 (typ.)	100	2.5	0.4	1000			8**	
5082-3379	1300 (typ.)	50		0.4				8**	
5082-3081	2500 (typ.)	100	3.5	0.4	1500			8**	
Test Conditions	$I_F = 50\text{ mA}$ $I_R = 250\text{ mA}$	$V_R = V_{BR}$ Measure $I_R \leq 10\ \mu\text{A}$	$I_F = 100\text{ mA}$ $f = 100\text{ MHz}$	$V_R = 50\text{ V}$ $f = 1\text{ MHz}$	$I_F = 0.01\text{ mA}$ $f = 100\text{ MHz}$	$I_F = 1.0\text{ mA}$ $I_F = 20\text{ mA}$ ** $f = 100\text{ MHz}$	Batch Matched at $I_F = 0.01\text{ mA}$ and 1.0 mA $f = 100\text{ MHz}$		