

**Silicon PNP Power Transistor**

**2SA1471**

**DESCRIPTION**

- DC Current Gain-  
:  $h_{FE} = 70(\text{Min}) @ (V_{CE} = -2V, I_C = -1A)$
- Low Saturation Voltage-  
:  $V_{CE(\text{sat})} = -0.4V(\text{Max}) @ (I_C = -5A, I_B = -0.25A)$
- Fast Switching Time
- Complement to Type 2SC3748

**APPLICATIONS**

- Various inductance lamp drivers for electrical equipment
- Inverters, converters (strobo, flash, fluorescent lamp lighting circuit).
- Power amp (high power car stereo, motor controller).
- High-speed switching (switching regulator, driver).

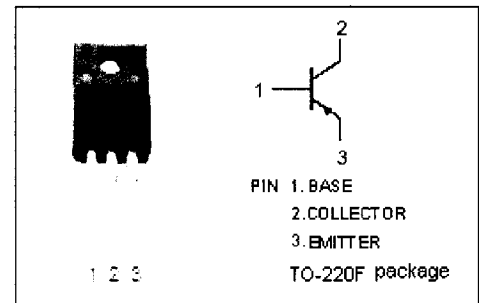

**ABSOLUTE MAXIMUM RATINGS ( $T_a = 25^\circ\text{C}$ )**

SYMBOL	PARAMETER	VALUE	UNIT
$V_{CBO}$	Collector-Base Voltage	-80	V
$V_{CEO}$	Collector-Emitter Voltage	-60	V
$V_{EBO}$	Emitter-Base Voltage	-5	V
$I_C$	Collector Current-Continuous	-10	A
$I_{CM}$	Collector Current-Peak	-12	A
$P_C$	Collector Power Dissipation @ $T_a = 25^\circ\text{C}$	2	W
	Collector Power Dissipation @ $T_C = 25^\circ\text{C}$	30	
$T_J$	Junction Temperature	150	$^\circ\text{C}$
$T_{stg}$	Storage Temperature	-55~150	$^\circ\text{C}$

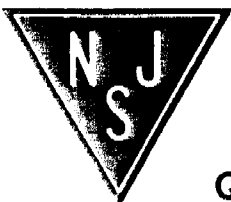
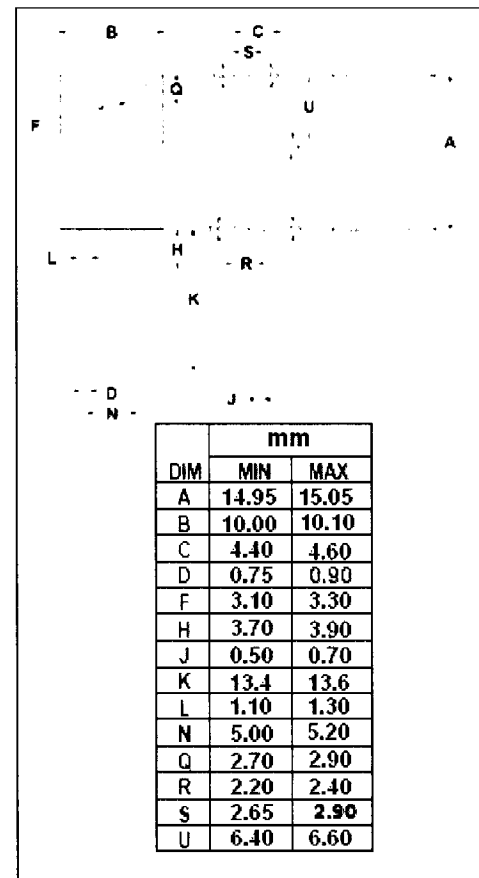

NJ Semi-Conductors reserves the right to change test conditions, parameter limits and package dimensions without notice. Information furnished by NJ Semi-Conductors is believed to be both accurate and reliable at the time of going to press. However, NJ Semi-Conductors assumes no responsibility for any errors or omissions discovered in its use. NJ Semi-Conductors encourages customers to verify that datasheets are current before placing orders.

# Silicon PNP Power Transistor

# 2SA1471

## ELECTRICAL CHARACTERISTICS

T<sub>j</sub>=25°C unless otherwise specified

SYMBOL	PARAMETER	CONDITIONS	MIN	TYP.	MAX	UNIT
V <sub>(BR)CEO</sub>	Collector-Emitter Breakdown Voltage	I <sub>C</sub> = -10mA; R <sub>BE</sub> = ∞	-60			V
V <sub>(BR)CBO</sub>	Collector-Base Breakdown Voltage	I <sub>C</sub> = -1mA; I <sub>E</sub> = 0	-80			V
V <sub>(BR)EBO</sub>	Emitter-Base Breakdown Voltage	I <sub>E</sub> = -1mA; I <sub>C</sub> = 0	-5			V
V <sub>CE(sat)</sub>	Collector-Emitter Saturation Voltage	I <sub>C</sub> = -5A; I <sub>B</sub> = -0.25A			-0.4	V
I <sub>CBO</sub>	Collector Cutoff Current	V <sub>CB</sub> = -40V; I <sub>E</sub> = 0			-100	μ A
I <sub>EBO</sub>	Emitter Cutoff Current	V <sub>EB</sub> = -4V; I <sub>C</sub> = 0			-100	μ A
h <sub>FE</sub>	DC Current Gain	I <sub>C</sub> = -1A; V <sub>CE</sub> = -2V	70		280	
f <sub>T</sub>	Current-Gain—Bandwidth Product	I <sub>C</sub> = -1A; V <sub>CE</sub> = -5V		100		MHz

### Switching Times

t <sub>on</sub>	Turn-on Time	I <sub>C</sub> = -5A, R <sub>L</sub> = 4Ω, I <sub>B1</sub> = -I <sub>B2</sub> = -0.25A, V <sub>CC</sub> = 20V		0.1		μ s
t <sub>stg</sub>	Storage Time			0.5		μ s
t <sub>f</sub>	Fall Time			0.1		μ s

### ◆ h<sub>FE</sub> Classifications

Q	R	S
70-140	100-200	140-280