

Silicon NPN Power Transistor

2SC4769

DESCRIPTION

- High Breakdown Voltage-
: $V_{CBO} = 1500V$ (Min)
- High Switching Speed
- High Reliability
- Built-in Damper Diode

APPLICATIONS

- Designed for ultrahigh-definition color display horizontal deflection output applications

ABSOLUTE MAXIMUM RATINGS ($T_a = 25^\circ C$)

SYMBOL	PARAMETER	VALUE	UNIT
V_{CBO}	Collector-Base Voltage	1500	V
V_{CEO}	Collector-Emitter Voltage	800	V
V_{EBO}	Emitter-Base Voltage	6	V
I_C	Collector Current- Continuous	7	A
I_{CP}	Collector Current-Pulse	16	A
P_C	Collector Power Dissipation @ $T_a = 25^\circ C$	3.0	W
	Collector Power Dissipation @ $T_c = 25^\circ C$	60	
T_J	Junction Temperature	150	$^\circ C$
T_{stg}	Storage Temperature Range	-55~150	$^\circ C$

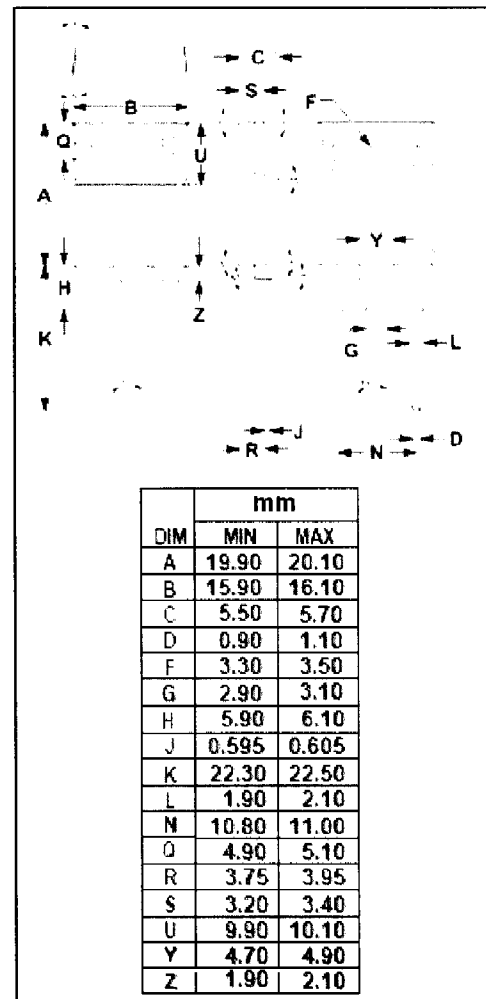
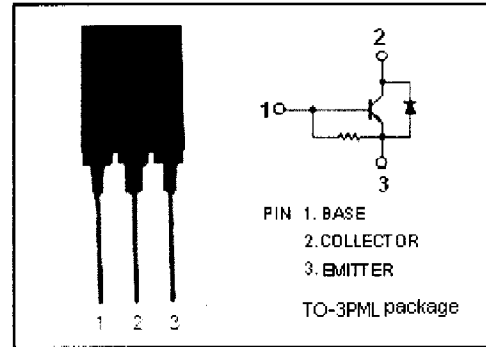

NJ Semi-Conductors reserves the right to change test conditions, parameter limits and package dimensions without notice. Information furnished by NJ Semi-Conductors is believed to be both accurate and reliable at the time of going to press. However, NJ Semi-Conductors assumes no responsibility for any errors or omissions discovered in its use. NJ Semi-Conductors encourages customers to verify that datasheets are current before placing orders.

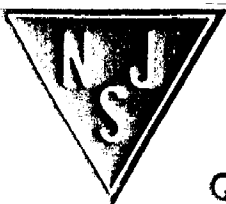

Silicon NPN Power Transistor

2SC4769

ELECTRICAL CHARACTERISTICS

$T_C=25^\circ\text{C}$ unless otherwise specified

SYMBOL	PARAMETER	CONDITIONS	MIN	TYP.	MAX	UNIT
$V_{CEO(SUS)}$	Collector-Emitter Sustaining Voltage	$I_C=100\text{mA}; I_B=0$	800			V
$V_{CE(sat)}$	Collector-Emitter Saturation Voltage	$I_C=5\text{A}; I_B=1.7\text{A}$			5.0	V
$V_{BE(sat)}$	Base-Emitter Saturation Voltage	$I_C=5\text{A}; I_B=1.7\text{A}$			1.5	V
I_{CBO}	Collector Cutoff Current	$V_{CB}=800\text{V}; I_E=0$			10	μA
I_{CES}	Collector Cutoff Current	$V_{CE}=1500\text{V}; R_{BE}=0$			1.0	mA
I_{EBO}	Emitter Cutoff Current	$V_{EB}=4\text{V}; I_C=0$	40		130	mA
h_{FE-1}	DC Current Gain	$I_C=1\text{A}; V_{CE}=5\text{V}$	8			
h_{FE-2}	DC Current Gain	$I_C=5\text{A}; V_{CE}=5\text{V}$	3		8	
V_{ECF}	C-E Diode Forward Voltage	$I_F=7\text{A}$			2.0	V

Switching times; Resistive load

t_{stg}	Storage Time	$I_C=4\text{A}; I_{B1}=0.8\text{A}; I_{B2}=-1.6\text{A}$ $R_L=33.3\ \Omega$			3.0	μs
t_f	Fall Time				0.2	μs

◆ h_{FE-2} Classifications

1	2	3
3-5	4-6	5-8