

2SK1089

F-III Series

> Features

- High Current
- Low On-Resistance
- No Secondary Breakdown
- Low Driving Power
- High Forward Transconductance

N-channel MOS-FET			
60V	0,035Ω	35A	80W

> Applications

- Motor Control
- General Purpose Power Amplifier
- DC-DC converters

> Outline Drawing

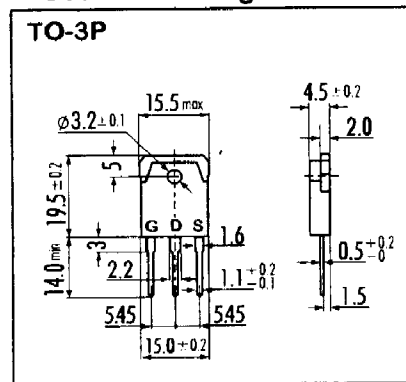

> Maximum Ratings and Characteristics

- Absolute Maximum Ratings (T_C=25°C), unless otherwise specified

Item	Symbol	Rating	Unit
Drain-Source-Voltage	V _{DS}	60	V
Continuous Drain Current	I _D	35	A
Pulsed Drain Current	I _{D(puls)}	140	A
Continuous Reverse Drain Current	I _{DR}	35	A
Gate-Source-Voltage	V _{GS}	±20	V
Max. Power Dissipation	P _D	80	W
Operating and Storage Temperature Range	T _{ch}	150	°C
	T _{stg}	-55 ~ +150	°C

> Equivalent Circuit

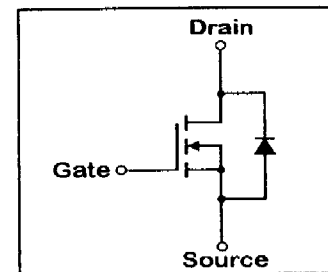

- Electrical Characteristics (T_C=25°C), unless otherwise specified

Item	Symbol	Test conditions	Min.	Typ.	Max.	Unit
Drain-Source Breakdown-Voltage	V _{(BR)DSS}	I _D =1mA V _{GS} =0V	60			V
Gate Threshold Voltage	V _{GS(th)}	I _D =1mA V _{DS} =V _{GS}	1,0	1,5	2,5	V
Zero Gate Voltage Drain Current	I _{DSS}	V _{DS} =60V T _{ch} =25°C		10	500	μA
		V _{GS} =0V T _{ch} =125°C		0,2	1,0	mA
Gate Source Leakage Current	I _{GSS}	V _{GS} =±20V V _{DS} =0V		10	100	nA
Drain Source On-State Resistance	R _{DS(on)}	I _D =17,5A V _{GS} =4V		0,037	0,056	Ω
		I _D =17,5A V _{GS} =10V		0,025	0,035	Ω
Forward Transconductance	g _{fs}	I _D =17,5A V _{DS} =25V	10	18		S
Input Capacitance	C _{iss}	V _{DS} =25V		1800	2700	pF
Output Capacitance	C _{oss}	V _{GS} =0V		620	930	pF
Reverse Transfer Capacitance	C _{rss}	f=1MHz		240	360	pF
Turn-On-Time t _{on} (t _{on} =t _{d(on)} +t _r)	t _{d(on)}	V _{CC} =30V		6	9	ns
		I _D =35A		60	90	ns
Turn-Off-Time t _{off} (t _{off} =t _{d(off)} +t _f)	t _{d(off)}	V _{GS} =10V		350	530	ns
		R _{GS} =25 Ω		150	230	ns
Diode Forward On-Voltage	V _{SD}	I _F =2xI _{DR} V _{GS} =0V T _{ch} =25°C		1,35	2,0	V
Reverse Recovery Time	t _{rr}	I _F =I _{DR} V _{GS} =0V		200		ns
		-dI _F /dt=100A/μs T _{ch} =25°C				

- Thermal Characteristics

Item	Symbol	Test conditions	Min.	Typ.	Max.	Unit
Thermal Resistance	R _{th(ch-a)}	channel to air			35	°C/W
	R _{th(ch-c)}	channel to case			1,56	°C/W

NJ Semi-Conductors reserves the right to change test conditions, parameter limits and package dimensions without notice. Information furnished by NJ Semi-Conductors is believed to be both accurate and reliable at the time of going to press. However, NJ Semi-Conductors assumes no responsibility for any errors or omissions discovered in its use. NJ Semi-Conductors encourages customers to verify that datasheets are current before placing orders.

