

**Standard Recovery Diodes  
 (Stud Version), 70 A**



DO-203AB (DO-5)

**FEATURES**

- High surge current capability
- Designed for a wide range of applications
- Stud cathode and stud anode version
- Leaded version available
- Types up to 1600 V  $V_{RRM}$

**TYPICAL APPLICATIONS**

- Converters
- Power supplies
- Machine tool controls
- Battery charges

**PRODUCT SUMMARY**

$I_{F(AV)}$	70 A
-------------	------

**MAJOR RATINGS AND CHARACTERISTICS**

PARAMETER	TEST CONDITIONS	70HF(R)		UNITS
		10 TO 120	140/160	
$I_{F(AV)}$		70	70	A
	$T_C$	140	110	°C
$I_{F(RMS)}$		110		A
$I_{FSM}$	50 Hz	1200		A
	60 Hz	1250		
$I^2t$	50 Hz	7100		A <sup>2</sup> s
	60 Hz	6450		
$V_{RRM}$	Range	100 to 1200	1400/1600	V
$T_J$		- 65 to 180	- 65 to 150	°C

**ELECTRICAL SPECIFICATIONS**

**VOLTAGE RATINGS**

TYPE NUMBER	VOLTAGE CODE	$V_{RRM}$ , MAXIMUM REPETITIVE PEAK REVERSE VOLTAGE V	$V_{RSM}$ , MAXIMUM NON-REPETITIVE PEAK REVERSE VOLTAGE V	$V_{R(BR)}$ , MINIMUM AVALANCHE VOLTAGE V	$I_{RRM}$ MAXIMUM AT $T_J = T_J$ MAXIMUM mA
70HF(R)	10	100	200	200	15
	20	200	300	300	
	40	400	500	500	
	60	600	720	725	
	80	800	960	950	9
	100	1000	1200	1150	
	120	1200	1440	1350	
	140	1400	1650	1550	
	160	1600	1900	1750	4.5

<b>FORWARD CONDUCTION</b>						
PARAMETER	SYMBOL	TEST CONDITIONS		70HF(R)		UNITS
				10 TO 120	140/160	
Maximum average forward current at case temperature	$I_{F(AV)}$	180° conduction, half sine wave		70		A
				140	110	°C
Maximum RMS forward current	$I_{F(RMS)}$			110		A
Maximum peak, one cycle forward, non-repetitive surge current	$I_{FSM}$	t = 10 ms	No voltage reappplied	1200		A
		t = 8.3 ms	No voltage reappplied	1250		
		t = 10 ms	100 % $V_{RRM}$ reappplied	1000		
		t = 8.3 ms	100 % $V_{RRM}$ reappplied	1050		
Maximum $I^2t$ for fusing	$I^2t$	t = 10 ms	No voltage reappplied	7100		$A^2s$
		t = 8.3 ms	No voltage reappplied	6450		
		t = 10 ms	100 % $V_{RRM}$ reappplied	5000		
		t = 8.3 ms	100 % $V_{RRM}$ reappplied	4550		
Maximum $I^2\sqrt{t}$ for fusing	$I^2\sqrt{t}$	t = 0.1 ms to 10 ms, no voltage reappplied		71 000		$A^2\sqrt{s}$
Low level value of threshold voltage	$V_{F(TO)1}$	$(16.7\% \times \pi \times I_{F(AV)} < I < \pi \times I_{F(AV)})$ , $T_J = T_J$ maximum		0.79		V
High level value of threshold voltage	$V_{F(TO)2}$	$(I > \pi \times I_{F(AV)})$ , $T_J = T_J$ maximum		1.00		
Low level value of forward slope resistance	$r_{f1}$	$(16.7\% \times \pi \times I_{F(AV)} < I < \pi \times I_{F(AV)})$ , $T_J = T_J$ maximum		2.33		mΩ
High level value of forward slope resistance	$r_{f2}$	$(I > \pi \times I_{F(AV)})$ , $T_J = T_J$ maximum		1.53		
Maximum forward voltage drop	$V_{FM}$	$I_{pk} = 220$ A, $T_J = 25$ °C, $t_p = 400$ μs rectangular wave		1.35	1.46	V

<b>THERMAL AND MECHANICAL SPECIFICATIONS</b>						
PARAMETER	SYMBOL	TEST CONDITIONS		70HF(R)		UNITS
				10 TO 120	140/160	
Maximum junction and storage temperature range	$T_J, T_{Stg}$			- 65 to 180	- 65 to 150	°C
Maximum thermal resistance, junction to case	$R_{thJC}$	DC operation		0.45		KW
Thermal resistance, case to heatsink	$R_{thCS}$	Mounting surface, smooth, flat and greased		0.25		
Maximum allowable mounting torque (+ 0 %, - 10 %)		Not lubricated thread, tightening on nut <sup>(1)</sup>		3.4 (30)	N · m (lbf · in)	
		Lubricated thread, tightening on nut <sup>(1)</sup>		2.3 (20)		
		Not lubricated thread, tightening on hexagon <sup>(2)</sup>		4.2 (37)		
		Lubricated thread, tightening on hexagon <sup>(2)</sup>		3.2 (28)		
Approximate weight				17	g	
				0.6	oz.	
Case style		See dimensions - link at the end of datasheet		DO-203AB (DO-5)		

# DO-203AB (DO-5) for 70HF(R)

**DIMENSIONS FOR 70HF(R) SERIES** in millimeters (inches)

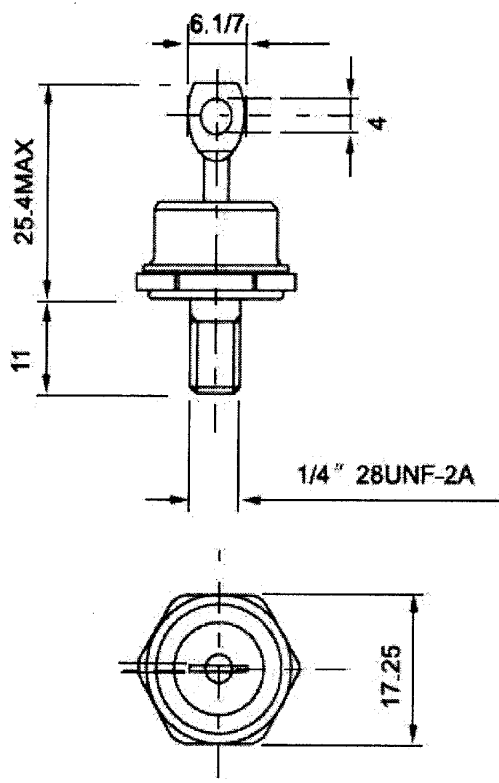

For metric devices: M6 × 1