

Triacs

Bidirectional Triode Thyristors

... designed primarily for full-wave ac control applications, such as light dimmers, motor controls, heating controls and power supplies.

- Blocking Voltage to 600 Volts
- All Diffused and Glass Passivated Junctions for Greater Parameter Uniformity and Stability
- Small, Rugged, Thermowatt Construction for Low Thermal Resistance, High Heat Dissipation and Durability
- T2800 — Four Quadrant Gating

**T2800
 SERIES**

**TRIACs
 8 AMPERES RMS
 200 thru 600 VOLTS**

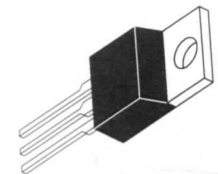

(TO-220AB)

MAXIMUM RATINGS ($T_J = 25^\circ\text{C}$ unless otherwise noted.)

Rating	Symbol	Value	Unit
Peak Repetitive Off-State Voltage ⁽¹⁾ ($T_J = -40$ to $+100^\circ\text{C}$, Gate Open)	V_{DRM}		Volts
		T2800 B D M	200 400 600
RMS On-State Current (Conduction Angle = 360°)	$I_{\text{T(RMS)}}$	8	Amps
Peak Non-repetitive Surge Current (One Full Cycle, 60 Hz, $T_J = +80^\circ\text{C}$)	I_{TSM}	100	Amps
Circuit Fusing ($t = 8.3$ ms)	I^2t	40	A^2s
Peak Gate Power (Pulse Width = 1 μs)	P_{GM}	16	Watts
Average Gate Power	$P_{\text{G(AV)}}$	0.35	Watt
Peak Gate Trigger Current (Pulse Width = 1 μs)	I_{GTM}	4	Amps
Operating Junction Temperature Range	T_J	-40 to +100	$^\circ\text{C}$
Storage Temperature Range	T_{stg}	-40 to +150	$^\circ\text{C}$

THERMAL CHARACTERISTICS

Characteristic	Symbol	Max	Unit
Thermal Resistance, Junction to Case	$R_{\theta\text{JC}}$	2.2	$^\circ\text{C/W}$

1. V_{DRM} for all types can be applied on a continuous basis. Blocking voltages shall not be tested with a constant current source such that the voltage ratings of the devices are exceeded.

NJ Semi-Conductors reserves the right to change test conditions, parameter limits and package dimensions without notice. Information furnished by NJ Semi-Conductors is believed to be both accurate and reliable at the time of going to press. However, NJ Semi-Conductors assumes no responsibility for any errors or omissions discovered in its use. NJ Semi-Conductors encourages customers to verify that datasheets are current before placing orders.



T2800 SERIES

ELECTRICAL CHARACTERISTICS (T_C = 25°C unless otherwise noted.)

Characteristic	Symbol	Min	Typ	Max	Unit
Peak Blocking Current (V _D = Rated V _{DRM} , Gate Open) T _C = 25°C T _C = 100°C	I _{DRM}	— —	— —	10 2	μA mA
Peak On-State Voltage (Either Direction)* (I _T = 30 A Peak)	V _{TM}	—	1.7	2	Volts
Gate Trigger Current (Continuous dc) (V _D = 12 Vdc, R _L = 12 Ohms) MT2(+), G(+) T2800 MT2(+), G(-) T2800 MT2(-), G(-) T2800 MT2(-), G(+) T2800	I _{GT}	— — — —	10 20 15 30	25 60 25 60	mA
Gate Trigger Voltage (Continuous dc) (All Polarities) (V _D = 12 Vdc, R _L = 100 Ohms) (R _L = 125 Ohms, V _D = V _{DRM} , T _C = 100°C)	V _{GT}	— 0.2	1.25 —	2.5 —	Volts
Holding Current (Either Direction) (V _D = 12 Vdc, Gate Open)	I _H	—	15	30	mA
Gate Controlled Turn-On Time (V _D = Rated V _{DRM} , I _T = 10 A, I _{GT} = 80 mA, Rise Time = 0.1 μs)	t _{gt}	—	1.6	—	μs
Critical Rate-of-Rise of Commutation Voltage (V _D = Rated V _{DRM} , I _T (RMS) = 8 A, Commutating di/dt = 4.1 A/ms, Gate Unenergized, T _C = 80°C)	dv/dt(c)	—	10	—	V/μs
Critical Rate-of-Rise of Off-State Voltage (V _D = Rated V _{DRM} , Exponential Voltage Rise, Gate Open, T _C = 100°C)	dv/dt	T2800 B D M	100 — — 60	— — — —	V/μs

*Pulse Test: Pulse Width ≤ 300 μs, Duty Cycle ≤ 2%.

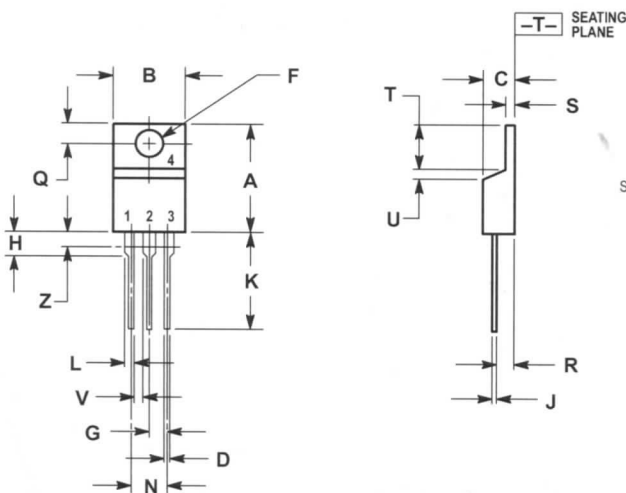

STYLE 4:
PIN 1. MAIN TERMINAL 1
2. MAIN TERMINAL 2
3. GATE
4. MAIN TERMINAL 2

- NOTES:
1. DIMENSIONING AND TOLERANCING PER ANSI Y14.5M, 1982.
2. CONTROLLING DIMENSION: INCH.
3. DIMENSION Z DEFINES A ZONE WHERE ALL BODY AND LEAD IRREGULARITIES ARE ALLOWED.

DIM	INCHES		MILLIMETERS	
	MIN	MAX	MIN	MAX
A	0.570	0.620	14.48	15.75
B	0.380	0.405	9.66	10.28
C	0.160	0.190	4.07	4.82
D	0.025	0.035	0.64	0.88
F	0.142	0.147	3.61	3.73
G	0.095	0.105	2.42	2.66
H	0.110	0.155	2.80	3.93
J	0.014	0.022	0.36	0.55
K	0.500	0.562	12.70	14.27
L	0.045	0.055	1.15	1.39
N	0.190	0.210	4.83	5.33
Q	0.100	0.120	2.54	3.04
R	0.080	0.110	2.04	2.79
S	0.045	0.055	1.15	1.39
T	0.235	0.255	5.97	6.47
U	0.000	0.050	0.00	1.27
V	0.045	—	1.15	—
Z	—	0.080	—	2.04