

BR1000 - BR1010

PRV : 50 - 1000 Volts

Io : 10 Amperes

FEATURES :

- * High current capability
- * High surge current capability
- * High reliability
- * Low reverse current
- * Low forward voltage drop
- * Rated isolation-voltage 2000 V_{AC}
- * Ideal for printed circuit board
- * Pb / RoHS Free

MECHANICAL DATA :

- * Case : Reliable low cost construction utilizing molded plastic technique
- * Epoxy : UL94V-0 rate flame retardant
- * Lead : Axial lead solderable per MIL - STD 202 , Method 208 guaranteed
- * Polarity : Polarity symbols marked on case
- * Mounting position : Any
- * Weight : 6.1 grams

SILICON BRIDGE RECTIFIERS

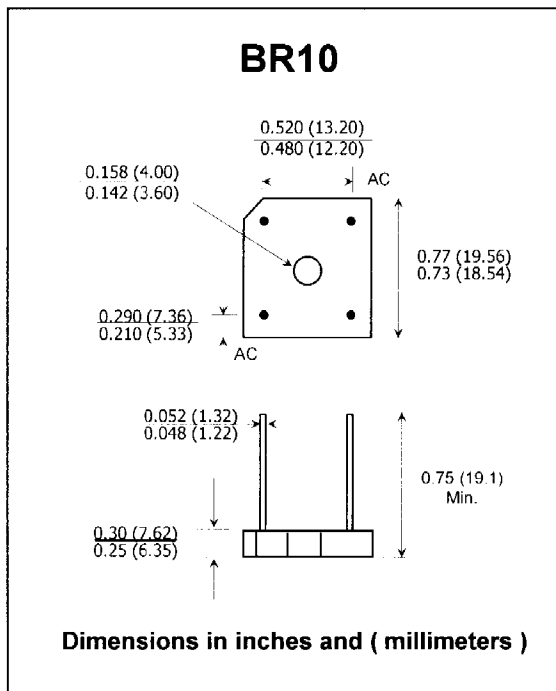

MAXIMUM RATINGS AND ELECTRICAL CHARACTERISTICS

Rating at 25 °C ambient temperature unless otherwise specified.
Single phase, half wave, 60 Hz, resistive or inductive load.
For capacitive load, derate current by 20%.

RATING	SYMBOL	BR1000	BR1001	BR1002	BR1004	BR1006	BR1008	BR1010	UNIT
Maximum Recurrent Peak Reverse Voltage	V _{RRM}	50	100	200	400	600	800	1000	V
Maximum RMS Voltage	V _{RMS}	35	70	140	280	420	560	700	V
Maximum DC Blocking Voltage	V _{DC}	50	100	200	400	600	800	1000	V
Maximum Average Forward Current T _c =55°C	I _{F(AV)}				10				A
Peak Forward Surge Current Single half sine wave Superimposed on rated load (JEDEC Method)	I _{FSM}				200				A
Current Squared Time at t < 8.3 ms.	I ² t				160				A ² S
Maximum Forward Voltage per Diode at I _F = 5 A	V _F				1.1				V
Maximum DC Reverse Current Ta = 25 °C	I _R				10				μA
at Rated DC Blocking Voltage Ta = 100 °C	I _{R(H)}				200				μA
Typical Thermal Resistance (Note 1)	R _{θJC}				2.5				°C/W
Operating Junction Temperature Range	T _J				- 40 to + 150				°C
Storage Temperature Range	T _{STG}				- 40 to + 150				°C

Note :

1. Thermal Resistance from junction to case with units mounted on a 3.2" x 3.2" x 0.12" (8.2cm x 8.2cm x 0.3cm.) Al.-Finned Plate.

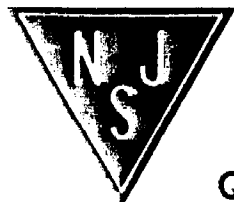

NJ Semi-Conductors reserves the right to change test conditions, parameter limits and package dimensions without notice. Information furnished by NJ Semi-Conductors is believed to be both accurate and reliable at the time of going to press. However, NJ Semi-Conductors assumes no responsibility for any errors or omissions discovered in its use. NJ Semi-Conductors encourages customers to verify that datasheets are current before placing orders.

Quality Semi-Conductors

RATING AND CHARACTERISTIC CURVES (BR1000 - BR1010)

FIG.1 - DERATING CURVE FOR OUTPUT RECTIFIED CURRENT

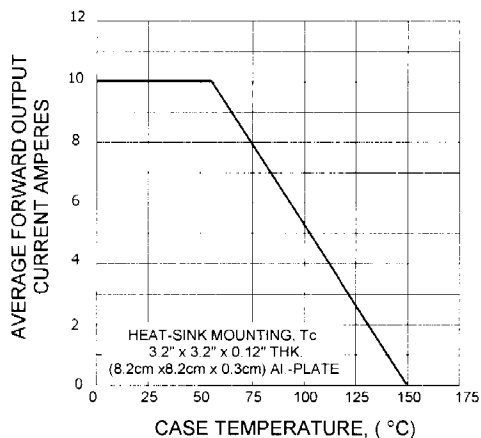

FIG.2 - MAXIMUM NON-REPETITIVE PEAK FORWARD SURGE CURRENT

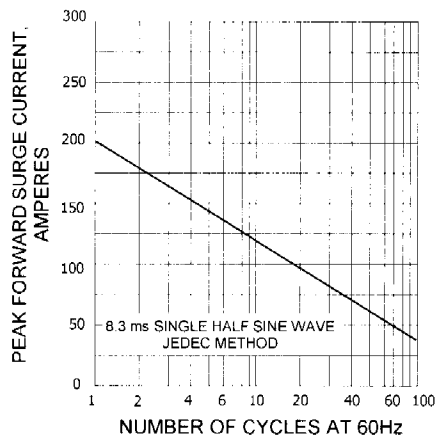

FIG.3 - TYPICAL FORWARD CHARACTERISTICS PER DIODE

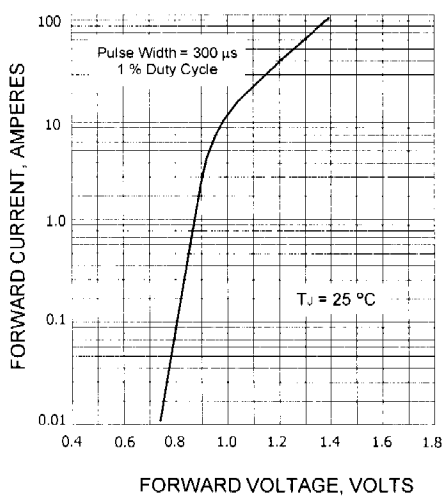

FIG.4 - TYPICAL REVERSE CHARACTERISTICS PER DIODE

