

Silicon NPN Power Transistor

BU407

DESCRIPTION

- High Voltage: $V_{CEV} = 330V(\text{Min})$
- Fast Switching Speed-
 : $t_f = 750ns(\text{Max})$
- Low Saturation Voltage-
 : $V_{CE(\text{sat})} = 1.0V(\text{Max}) @ I_C = 5A$

APPLICATIONS

- Designed for use in horizontal deflection output stages of TV's and CRT's

ABSOLUTE MAXIMUM RATINGS($T_a = 25^\circ\text{C}$)

SYMBOL	PARAMETER	VALUE	UNIT
V_{CBO}	Collector-Base Voltage	330	V
V_{CEV}	Collector-Emitter Voltage	330	V
V_{CEO}	Collector-Emitter Voltage	150	V
V_{EBO}	Emitter-Base Voltage	6	V
I_C	Collector Current-Continuous	7	A
I_{CP}	Collector Current-Peak Repetitive	10	A
I_{CP}	Collector Current- Peak (10ms)	15	A
I_B	Base Current	4	A
P_C	Collector Power Dissipation @ $T_c = 25^\circ\text{C}$	60	W
T_J	Junction Temperature	150	$^\circ\text{C}$
T_{stg}	Storage Temperature Range	-65~150	$^\circ\text{C}$

THERMAL CHARACTERISTICS

SYMBOL	PARAMETER	MAX	UNIT
$R_{th\ j-c}$	Thermal Resistance, Junction to Case	2.08	$^\circ\text{C/W}$
$R_{th\ j-a}$	Thermal Resistance, Junction to Ambient	70	$^\circ\text{C/W}$

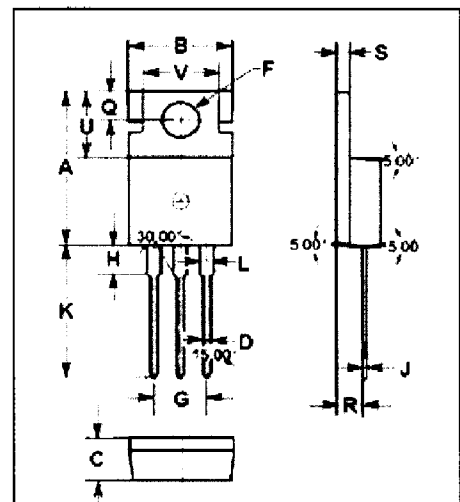
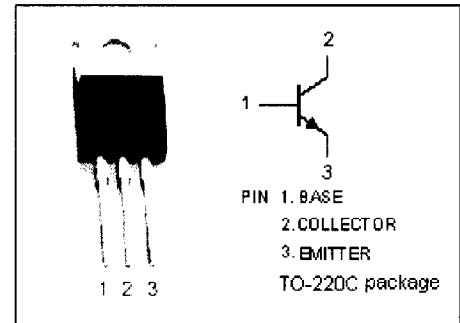

DIM	mm	
	MIN	MAX
A	15.70	15.90
B	9.90	10.10
C	4.20	4.40
D	0.70	0.90
F	3.40	3.60
G	4.98	5.18
H	2.70	2.90
J	0.44	0.46
K	13.20	13.40
L	1.10	1.30
Q	2.70	2.90
R	2.50	2.70
S	1.29	1.31
U	6.45	6.65
V	8.66	8.86

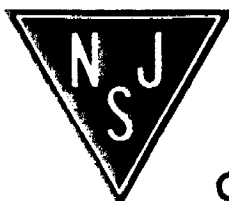

NJ Semi-Conductors reserves the right to change test conditions, parameter limits and package dimensions without notice. Information furnished by NJ Semi-Conductors is believed to be both accurate and reliable at the time of going to press. However, NJ Semi-Conductors assumes no responsibility for any errors or omissions discovered in its use. NJ Semi-Conductors encourages customers to verify that datasheets are current before placing orders.

Quality Semi-Conductors

Silicon NPN Power Transistor

BU407

ELECTRICAL CHARACTERISTICS

$T_C=25^\circ\text{C}$ unless otherwise specified

SYMBOL	PARAMETER	CONDITIONS	MIN	TYP.	MAX	UNIT
$V_{CE(sus)}$	Collector-Emitter Sustaining Voltage	$I_C=100\text{mA}; I_B=0$	150			V
$V_{CE(sat)}$	Collector-Emitter Saturation Voltage	$I_C=5\text{A}; I_B=0.5\text{A}$			1.0	V
$V_{BE(sat)}$	Base-Emitter Saturation Voltage	$I_C=5\text{A}; I_B=0.5\text{A}$			1.2	V
I_{CES}	Collector Cutoff Current	$V_{CE}=330\text{V}; V_{BE}=0$ $V_{CE}=200\text{V}; V_{BE}=0$ $V_{CE}=200\text{V}; V_{BE}=0; T_C=150^\circ\text{C}$			5.0 0.1 1.0	mA
I_{EBO}	Emitter Cutoff Current	$V_{EB}=6\text{V}; I_C=0$			1.0	mA
f_T	Current-Gain—Bandwidth Product	$I_C=0.5\text{A}; V_{CE}=10\text{V}; f_{test}=20\text{MHz}$	10			MHz
C_{OB}	Output Capacitance	$I_E=0; V_{CB}=10\text{V}; f_{test}=1.0\text{MHz}$		80		pF
t_f	Fall Time	$I_C=5\text{A}; I_{B1}=-I_{B2}=0.5\text{A}; L=150\mu\text{H}; V_{CC}=40\text{V}$			0.75	μs